

Test report

P 10619-1a-E

Commission:	Initial tests of the product
	UNIFIX®-S3
	as a mortar according to EN 12004
Costumer:	Schomburg GmbH & Co. KG Aquafinstraße 2-8 32760 Detmold
Persons in charge:	Dipl.-Ing. (FH) N. Machill Dipl.-Ing. (FH) A. Kruse
test period:	14.12.2016 - 28.02.2017
Date of the test report:	2017-04-18
This test report comprises:	13 pages including 1 annex

This test report replaces test report P 10619 dated 2017-04-06.
The test results refer exclusively to the materials tested.
The publication of reports, also in extracts, and references to tests for advertising purposes require our written agreement in each individual case.

C O N T E N T S

1	SUBJECT	3
2	RECEIPT OF SAMPLES	3
3	PREPARATION OF THE SPECIMENS	3
4	TESTS	4
4.1	Tensile adhesion strength	4
4.1.1	Initial tensile adhesion strength	5
4.1.2	Tensile adhesion strength after water contact	6
4.1.3	Tensile adhesion strength after heat ageing	7
4.1.4	Tensile adhesion strength after freeze/thaw cycle	8
4.2	Extended open time: tensile adhesion strength	9
4.3	Determination of slip	9
4.4	Determination of transverse deformation	11
5	SUMMARY	12
	ANNEX 1	13

1 SUBJECT

Polymer Institut was charged by Schomburg GmbH & Co. KG, Detmold, to carry out tests on the mortar

UNIFIX®-S3

according to DIN EN 12004:02-2014 „Adhesives for tiles – Requirements, evaluation of conformity, classification and designation“.

2 RECEIPT OF SAMPLES

On 2016-12-14 the following substances were delivered to Polymer Institut. Until testing the samples were stored at standard conditions according to DIN EN 23270.

table 1: receipt of samples

Pos.	substance	component	quantity [kg]
1	UNIFIX®-S3	A	15
2	UNIFLEX®-F	B	5

3 PREPARATION OF THE SPECIMENS

The mixture ratio for UNIFIX®-S3 can be seen in the following overview.

Overview 1: mixture ratio

substance	parts by weight*	
	UNIFIX®-S3	UNIFLEX®-F
UNIFIX®-S3	3	1

* the resulting mixture was mixed with 1.35% water

The mixture and application was done by an employee of Polymer Institut at standard conditions according to EN 23270.

UNIFLEX®-F was given into a mortar mixer according to DIN EN 196-1:05-1995 „Methods of testing cement – Determination of strength“ followed by the powder component UNIFIX®-S3, which was given into the mixer under stirring (level 1).

The material was mixed for about 30 seconds, until a homogeneous mass was reached. During of 60 seconds the material was put back from the mixer edge. After a maturing time of 3 minutes, the material was mixed for another 15 seconds.

Overview 2: consumption mean values and applicator

layer	consumption [g/m ²]	applicator
scratch filler	306	smoothing trowel
adhesive	2175	notched trowel (6 x 6 mm) ¹⁾

¹⁾ angle between specimen surface and notched trowel about 60°

For the tensile adhesion strength and the extended open time tests concrete slabs (400 x 400) mm² were coated as shown in the overview above. 10 tiles of the type V1 according to EN 14411 (50 x 50 x 4) mm³ were laid in the adhesive layer and were loaded with 20 N for 30 seconds.

For the determination to slip test tiles of the type V2 according to EN 14411 (100 x 100 x 8) mm³ were laid in the adhesive layer and were loaded with 50 N for 30 seconds.

For the determination of transverse deformation free films of UNIFIX®-S3 with the dimensions 45 x 280 x 3 mm³ were produced with the help of templates according to DIN EN 12002:01-2009 "Adhesives for tiles – Determination of transverse deformation for adhesives and grouts".

4 TESTS

The performed tests can be seen in the following overview.

overview: *performed tests*

chapter in the report	test	reference
4.1	tensile adhesion strength	DIN EN 1348
4.2	extended open time: tensile adhesion strength	DIN EN 1346
4.3	determination of slip	DIN EN 1308
4.4	determination of transverse deformation	DIN EN 12002

4.1 Tensile adhesion strength

The tests of the tensile adhesion strength were performed according to DIN EN 1348:11-2007 „Adhesive for tiles – Determination of tensile adhesion strength for cementitious adhesives“, with the following conditions.

testing machine: Fa. Freundl, Typ Easy M 10
testing speed: 250 ± 50 N/s
stamp dimension: 50 mm x 50 mm
adhesive (tie rod): 2 K-PUR
pre-storage: can be seen in the following chapters

The tensile adhesion strength is designated for each series:

- *Determination of the mean value of 10 values*
- *Discharging the values out of the range of ± 20 % from the mean value.*
- *If five or more than five values remain, a new mean value is determined.*

Area of failure:

- CF-S cohesion failure within the substrate
 AF-S adhesion failure between tile adhesive and substrate
 CF-A cohesion failure within tile adhesive
 AF-T adhesion failure between tile adhesive and tile
 CF-T cohesion failure within the tile
 BF adhesion failure between tile adhesive and tie rod – steel plate

4.1.1 Initial tensile adhesion strength

The test of the tensile adhesion strength was performed after storage of 28 days at standard conditions. The results can be seen in the following table.

table 2: initial tensile adhesion strength

no	tensile adhesion strength [N/mm ²]	area of failure* [%]	
		CF-A	AF-T
1	2,4	50	50
2	2,2	40	60
3	2,5	30	70
4	2,3	40	60
5	2,5	50	50
6	2,6	60	40
7	2,5	50	50
8	2,4	50	50
9	2,5	60	40
10	2,6	40	60
mean value	2,5		

* legend area of failure, see page 5
 (..) not included in the calculation of the mean value

4.1.2 Tensile adhesion strength after water contact

The specimen was stored for 7 days at standard conditions followed by storage of 20 days under a head of water of 6 mm. The tie rods were glued on the tiles and after storage under a head of water of 6 mm for 24 hours the tensile adhesion strength was determined. The results can be seen in the following table.

table 3: *tensile adhesion strength after contact with water*

no	tensile adhesion strength [N/mm ²]	area of failure* [%]
		AF-T
1	1,1	100
2	1,3	
3	1,2	
4	1,0	
5	1,0	
6	1,1	
7	1,1	
8	1,1	
9	1,1	
10	1,1	
mean value	1,1	

* *legend area of failure, see page 5*

(..) *not included in the calculation of the mean value*

4.1.3 Tensile adhesion strength after heat ageing

The specimen was stored for 14 days under standard conditions and afterwards for 14 days in a drying chamber at 70 °C. After gluing the tie rods, the specimen was stored for 24 hours under standard conditions until the test was performed. The results can be seen in the following table.

table 4: *tensile adhesion strength after heat ageing*

no.	tensile adhesion strength [N/mm ²]	area of failure* [%]		
		CF-S	CF-A	AF-T
1	2,8		40	60
2	2,9		10	90
3	2,6		10	90
4	2,7		10	90
5	2,6		10	90
6	3,2		40	60
7	2,9		20	80
8	2,4		20	80
9	2,8		20	80
10	2,6	30		70
mean value	2,8			

* *legend area of failure, see page 5*

(..) *not included in the calculation of the mean value*

4.1.4 Tensile adhesion strength after freeze/thaw cycle

Differing to the production of the other specimens an about 1 mm thick layer of the tile adhesive was applied on the backside of the tiles before gluing them on the specimen. After the application the specimen was stored for 7 days under standard conditions following by storage of 21 days under water. Immediately after withdrawal out of the water the specimen was subjected with the following freeze/thaw cycle for 25 times.

- withdrawal out of the water and reduce the temperature to $-15 \pm 3 \text{ }^\circ\text{C}$ within $2 \text{ h} \pm 20 \text{ min}$
- storage of the specimen at $-15 \pm 3 \text{ }^\circ\text{C}$ for $2 \text{ h} \pm 20 \text{ min}$
- storage of the specimen in water and hold the temperature at $15 \pm 3 \text{ }^\circ\text{C}$

The execution of the freeze/thaw cycle was performed in an automatic climate box of the company Weiss. After reaching the standard temperature the test of the tensile adhesion strength was performed.

The results can be seen in the following table.

table 5: *tensile adhesion strength after freeze/thaw cycle*

no.	tensile adhesion strength [N/mm ²]	area of failure* [%]
		CF-A
1	1,3	100
2	1,4	
3	1,4	
4	1,5	
5	1,3	
6	1,4	
7	1,2	
8	1,5	
9	1,5	
10	1,4	
mean value	1,4	

* *legend area of failure, see page 5*

(..) *not included in the calculation of the mean value*

4.2 Extended open time

The test of the extended open time: tensile adhesion strength was performed according to DIN EN 1346:11-2007 “Adhesives for tiles – Determination of open time”.

The tile adhesive was mixed and applied according to chapter 3. The tiles (50 x 50 x 4) mm³ were laid into the tile adhesive after 30 minutes. Each tile was loaded with 20 N for 30 seconds.

Until the test of the tensile adhesion strength the specimens were stored for 28 days at standard conditions according to DIN EN 23270.

The results can be seen in the following table.

table 6: tensile adhesion strength – application of tiles after 30 min

no.	tensile adhesion strength [N/mm ²]	area of failure*
		[%]
		AF-T
1	0,6	100
2	(0,7)	
3	(0,7)	
4	0,5	
5	(0,3)	
6	0,5	
7	0,4	
8	(0,7)	
9	0,4	
10	0,5	
mean value	0,5	

* legend area of failure, see page 5

(..) not included in the calculation of the mean value

4.3 Determination of slip

The determination of slip was performed according to DIN EN 1308:11-2007 “Adhesives for tiles – Determination of slip” on 3 tiles.

The tile adhesive was mixed and applied according to chapter 3. Vertical to the direction of application a steel ruler was placed parallel to specimen edge. Beneath, parallel to the steel ruler a 25 mm wide tape strip was glued. The application of the tile adhesive took place with a notched trowel (see chapter 3) until the steel ruler, so that after the removal of the tape a parallel to the steel ruler position edge results. The tiles (100 x 100 x 8) mm³ were laid with the help of spacers into the tile adhesive and were loaded with 50 N for 30 seconds.

The whole test layout can be seen in the following figure.

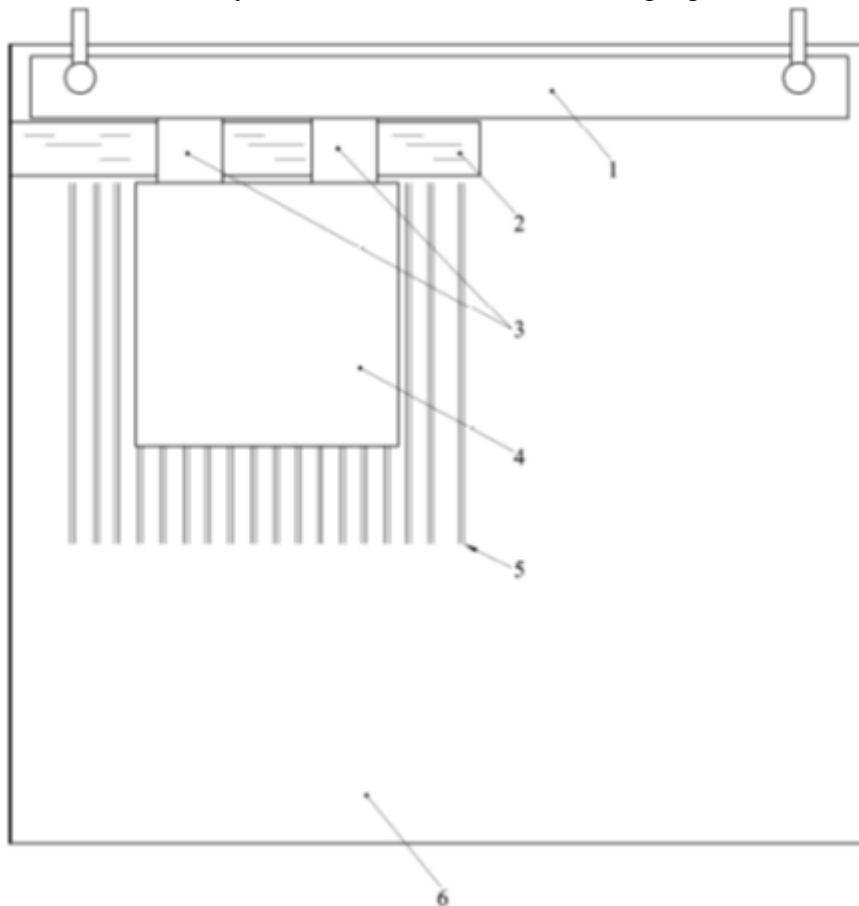

figure 1: application equipment for the determination of slip (DIN EN 1308, figure 1)

Legend:

- 1) steel ruler 2) tape 25 mm wide 3) spacer
4) tile 5) tile adhesive 6) concrete slab

The distance between the steel ruler and the tiles were measured to 0.1 mm accuracy. Afterwards the specimen was placed in a vertical position. After 20 minutes the distance was measured again.

table 7: result – determination of slip UNIFIX®-S3

specimen	Determination of slip [mm]	mean value [mm]
1	0.2	0,2
2	0.2	
3	0.1	

4.4 Determination of transverse deformation

The determination of transverse deformation was performed according to DIN EN 12002:01-2009 “*Determination of transverse deformation for cementitious adhesives and grouts*” on three specimens.

The mixing and the specimen production can be seen in chapter 3 of this report.

The templates which were used to produce the specimens were removed after 2 days. The specimens were now stored in an air tight box under standard conditions according DIN EN 23270 for 12 days, following of a storage under standard conditions for 14 days.

The test of the transverse deformation was performed on a path controlled testing machine UPM 1445 of the company Zwick with the help of a 3 point bending equipment. The test speed was 2 mm/min. In the following figure the test installation can be seen.

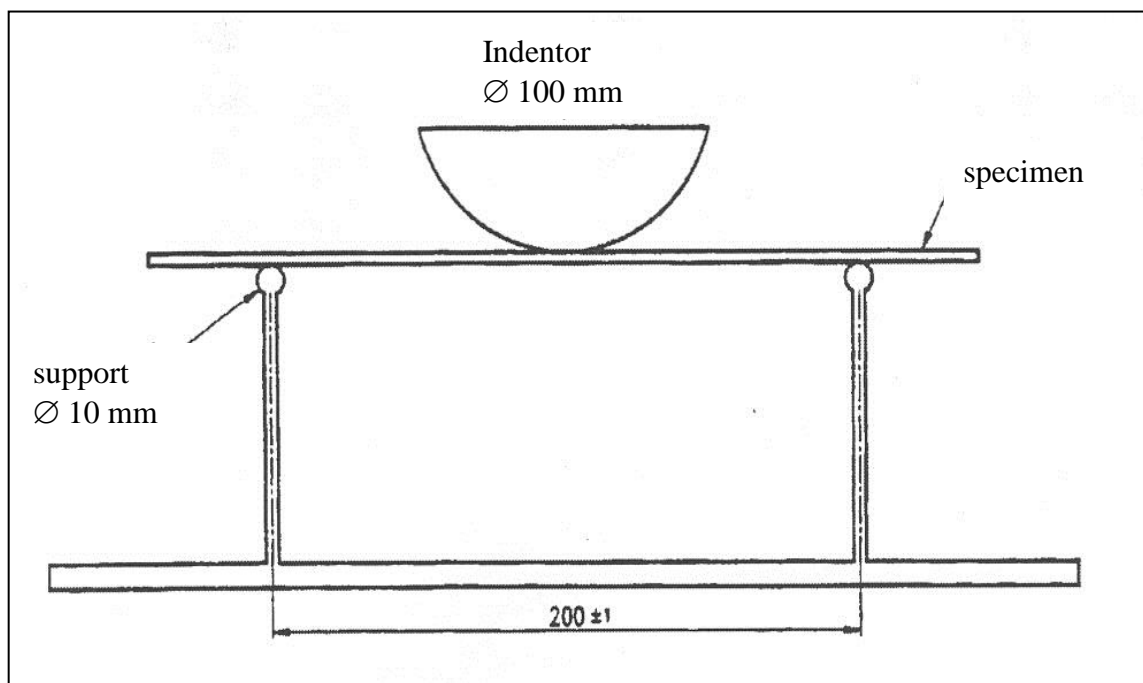

figure 1: test of transverse deformation; test installation (DIN EN 12002, figure 2)

The results are summarized in the following table.

table 8: *transverse deformation UNIFIX[®]-S3*

specimen no	max. deformation [mm]
1	11.8
2	8.1
3	9.2
mean value	9.7

5 SUMMARY

In charge of Schomburg GmbH & Co. KG, Detmold, tests were performed on the mortar

UNIFIX®-S3

according to DIN EN 12004:02-2014 „Adhesives for tiles – Requirements, evaluation of conformity, classification and designation“.

The results of the tests can be seen in chapter 4 and are summarized in annex 1.

The mortar UNIFIX®-S3 corresponds to the following classification according to DIN EN 12004:

***C 2TE S2 strongly deformable setting
cementitious mortar
for increased requirements
with reduced slip
and extended open time***

Flörsheim-Wicker, 2017-04-18

vice head of institute

A handwritten signature in blue ink, appearing to read "N. Machill".

Dipl.-Ing. (FH) N. Machill

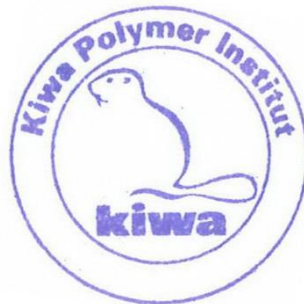

person in charge

A handwritten signature in blue ink, appearing to read "Andreas Kruse".

Dipl.-Ing. (FH) A. Kruse

ANNEX 1

overview: **UNIFIX[®]-S3**

chapter in the report	test	result	Requirement ¹⁾
4.1	tensile adhesion strength [N/mm ²] - initial tensile adhesion strength - after water contact - after heat ageing - after freeze/thaw cycle	2,5 1,1 2,8 1,4	≥ 1,0
4.2	extended open time [N/mm ²] application time after 30 min	0,5	
4.3	determination of slip [mm]	0,2	≤ 0,5
4.4	transverse deformation [mm]	9,7	≥ 5,0

Remark:

¹⁾ according to DIN EN 12004